

Type \_\_\_\_\_  
 -80 -102  
 P4571

Catalog No.	Finish		Lamping	Dimensions (Inches)			
	Black	Java		A	B	C	D
P4571	-80	-102	3 (m) 100w	9	37-1/4	18	93

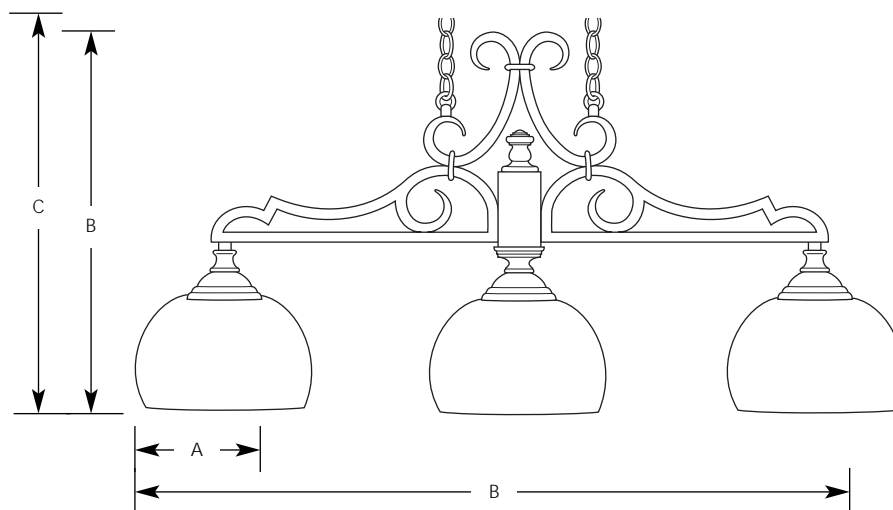

**Specifications:**

General

- Antique swirl art glass shades
- Linear chandelier style
- Scrolled metalwork
- Square arms
- Painted finish
- 6 feet of 9 gauge chain supplied
- Steel Construction
- Companion chandeliers, hall and foyer, wall bracket, and close to ceiling units

Electrical

- Ceramic medium based sockets
- 15 feet of wire supplied
- Pre-wired

Labeling

- UL-CUL listed

Mounting

- Ceiling chain mounted
- Canopy covers a standard 4" hexagonal outlet box
- Mounting strap for outlet box included